

PNEUMATIC POLYURETHANE TUBE

CPU Series

Copely



Suitable for a wide range of applications, such as pneumatic control systems, demanding a flexible and cut-resistant tube with maximum kink-resistance and minimum kink memory.

Key Features:

- Low temperature flexibility.
- Exceptional abrasion resistance.
- Maximum kink-resistance; minimum kink memory.
- Resistant to a wide range of chemicals.
- Compliant with FDA regulations.
- Easy to fit in confined spaces.
- Meets the standards of the push fit type couplings.
- Silicone free.
- 95/98 Shore A hardness.
- Service Temperature -40°C – +80°C.
- 4:1 safety factor.
- RoHS 3 compliant.

Sizes:

- Available from stock in 30 m coils

Colours:

- Blue, black, red, clear, yellow and green

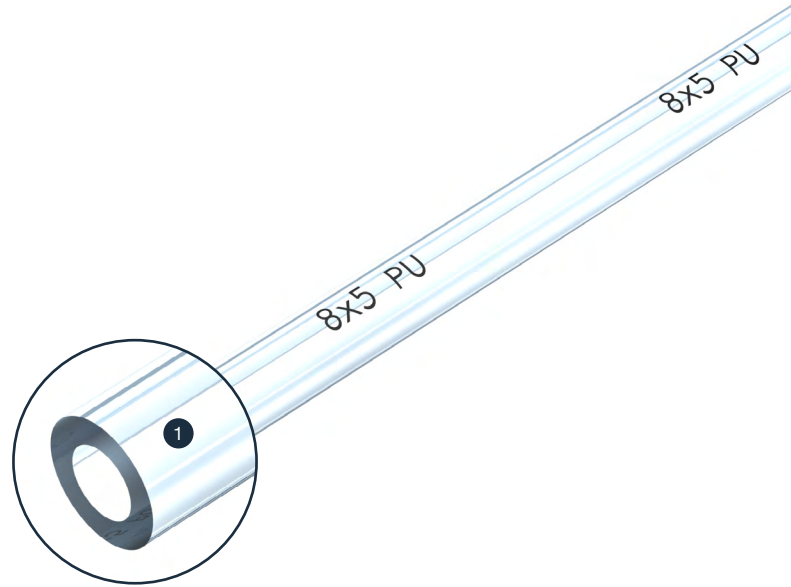

1. Ester based polyurethane



Applications:

- Pneumatic control systems/tools
- Fuel and lubrication lines
- Chemical transfer
- Food/liquid substances



Product Ref	Internal Diameter	External Diameter	Maximum Working Pressure	Minimum Burst Pressure	Weight per Metre	Bend Radius
CPU04	2.5 mm	4 mm	11 Bar	40 Bar	0.010 Kg	25 mm
CPU06	4 mm	6 mm	10 Bar	40 Bar	0.023 Kg	40 mm
CPU08	5 mm	8 mm	10 Bar	40 Bar	0.040 Kg	50 mm
CPU10	7.5 mm	10 mm	7.5 Bar	30 Bar	0.044 kg	75 mm
CPU12	8 mm	12 mm	6.5 Bar	26 Bar	0.069 kg	90 mm